

Maintain flow of stored material

Standard Industrie International is an international group specializing in the engineering and manufacture of industrial equipment for the handling, storage and transportation of bulk materials. Its innovative solutions help to improve production performance and efficiency, reduce maintenance costs and risks, and ensure a safer working environment.

THE PREVENTIVE SOLUTION : AIRCHOC AIR CANNON

For example, Standard Industrie's long-standing AIRCHOC® air cannon solution has been helping numerous plants for over 40 years to prevent clogging of the material stored in their silos, and consequently to avoid production stoppages.

With a wide range of products (tank capacities from 4 liters to 400 liters), this preventive system can be adapted to a wide variety of bulk applications.

Following a technical audit, AIRCHOC® can be placed in various locations on raw material storage units (sand, flour, wood shavings, peat, straw, mulch, etc.).

AIRCHOC® acts preventively on the material, with regular programmed shots.

It's an economical solution that uses only air, and only when the shots are activated.

This cleaning solution eliminates material deposits in storage units and material conveyors.

CUSTOMER CASE, FOR EXAMPLE:

This animal feed plant has a cylindrical bran storage unit equipped with a rectangular multi-screw unloader (photo 1). In the transition section from round to rectangular above the unloader, bran accumulates regularly until extraction, and therefore production, comes to a complete standstill. (photo 2)

Standard Industrie proposed the installation of 4 AIRCHOC® air cannons on the storage unit (photo 3) and guaranteed that no clogging problems would occur as long as the AIRCHOC® were in service, in accordance with the predetermined location and firing sequence. Since February 2021, AIRCHOC® have been working on the silo with good results. The customer is satisfied and has placed an order for a further 12 air cannons for a 4-compartment soy silo.

THE CURATIVE SOLUTION: GIRONET CLEANING SYSTEM

As a curative solution, Standard Industrie International also offers a complete

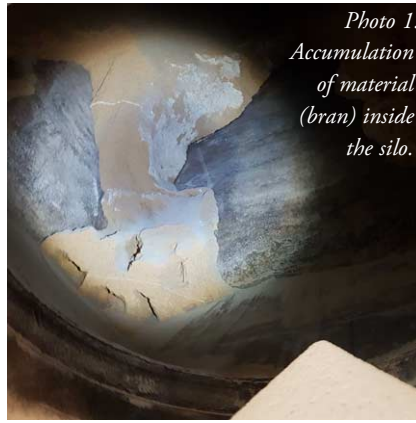

Photo 1. Accumulation of material (bran) inside the silo.



Photo 2. AIRCHOC placed to act directly on the stored material.



Photo 3. Cylindrical unit for bran storage, equipped with 4 AIRCHOC air cannons.

storage unit cleaning service, which enables the storage capacity of clogged or congested silos or hoppers to be recovered. This service is carried out using the POWERNET and GIRONET (photo 4), guaranteeing safe intervention from the top of the silo.

The articulated arm of the GIRONET which rotates at 360° eliminates the rat holing problems.

This solution meets stringent safety standards: It avoids having any human presence inside silos.

The GIRONET intervention will enable to increase the capacity of collection in order to avoid supply disruptions.

The GIRONET is effective on any type of blockage, product or storage unit. It can be used without stopping production.

Also, declogging with the POWERNET

Photo 4. Gironet.

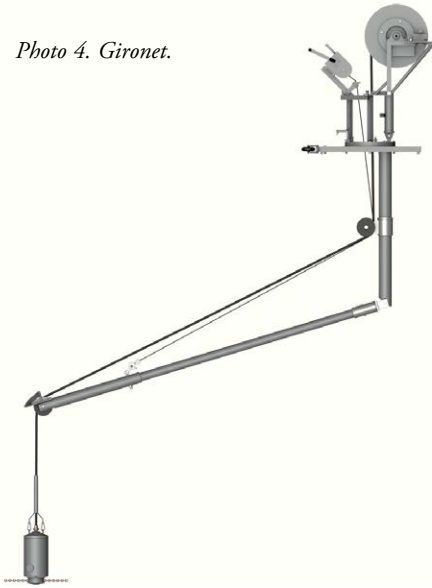

Photo 5. Before silo cleaning started. Completely bridged.



Photo 6. Bran silo that has been cleaned with the ATEX Gironet application.



will solve bridging problems through safe breaking down of the clogged material to help it flow more freely. The POWERNET is used before the GIRONET when the storage unit is completely blocked. Idea of the POWERNET is to create a chimney through which the GIRONET will be used to sag down the build-ups.

CUSTOMER CASE, FOR EXAMPLE:

The customer, a leader in the food industry, had bran stored in two of their silos that had both bridged and they did not have flow of material from these silos. They wanted to clean the silos by

removing all the material hanging inside of the silo and regain full silo capacity on both Bran silos. Customer has been using cardox with mixed results in terms of performance and safety.

The customer heard of the Gironet solution from another plant of the group where Standard Industrie did a similar Powernet/ATEX Gironet intervention on a Bran silo too. They asked if we would be able to clean to their Bran silos. Standard Industrie conducted a site inspection and concluded that they would be able to assist them. First, the Powernet was used for penetration of the bridged material and

then our deported ATEX Gironet was applied to clean the material inside of the silo with Brass chains. This was applied to both Bran silos with the customer having regained full capacity at the end of the intervention. Both silos were cleaned in 7 working days. The customer obtained the results that he expected. (Photos 5 & 6)

Regardless of the cleaning solution chosen by its customers, Standard Industrie meets the dual challenge of maintaining a high level of maintenance to guarantee production flow, while keeping costs to a minimum.